



# **Ergosys rail**

## **The Ergosys Rail® Edge**

### **FREE STANDING WORKSTATION BRIDGE CRANES**

#### **250 & 500lb capacity**

Ergo Sys Rail Work Station Cranes combine superior quality and are ergonomically designed to solve your material handling needs. Our heavy duty construction provides a product which will offer long term reliability for years to come. THANK YOU FOR CHOOSING ERGO SYS RAIL WORK STATION CRANES.

All Ergo Sys Rail Cranes are pre-engineered for our VacuHoist vacuum lifting system. The VacuHoist plus trolley weight allowance is 15% of the crane capacity. By following the installation and maintenance procedures described herein, your Ergo Sys Workstation crane will provide many years of dependability service.

Model # \_\_\_\_\_ Purchase Date: \_\_\_\_\_

#### **FREE STANDING & WALL MOUNT WORK STATION JIB CRANES INSTALLATION AND MAINTENANCE MANUAL**

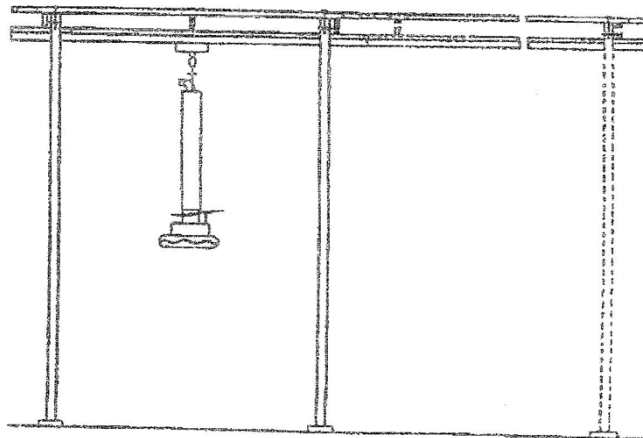

**IT IS THE CUSTOMER'S RESPONSIBILITY TO ENSURE THAT THEIR BUILDING OR SUPER  
STRUCTURE IS ADEQUATE TO SUPPORT THE LOADING SHOWN.**

## 1.0 Installing Post/Header Assembly

- 1.1 Place upright post and header panel on smooth floor surface.
- 1.2 Using header clamp plates and 5/8" all thread rod, assemble header to upright post. (FIG 1)
- 1.3 Tighten to 100 ft. lbs. of torque.
- 1.4 Stand assembled unit upright in position.
- 1.5 Repeat the above steps for each additional set of upright supports.
- 1.6 When all upright supports are in place, secure to floor using 3/4" anchor bolts.

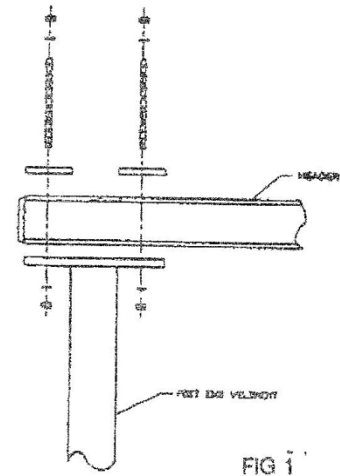

FIG 1

## 2.0 Installing Runways

- 2.1 Place runway in the position that will be supported by two upright assemblies. (FIG 2)
- 2.2 Using header clamp plates and 5/8" allthread rod, attach to header assembly.
- 2.3 Repeat for second runway.

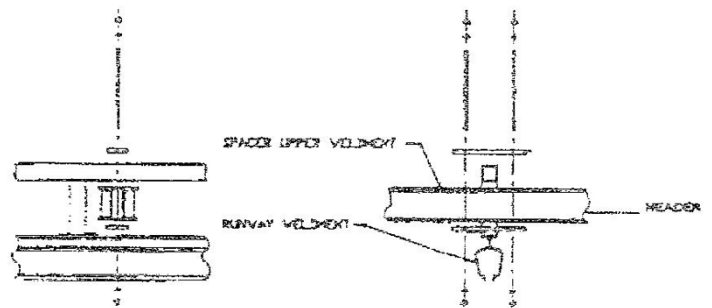

FIG 2

## 3.0 Splicing Runway Sections

- 3.1 Using 5/16" bolt splice kit (supplied) attach runways. (FIG 3A)
- 3.2 To connect runway trusses, align truss splice plates to runway truss and bolt together. (FIG 3B)  
NOTE: There should not be any edges showing that would cause the trolley to catch or bind.
- 3.3 Check alignment. Adjust if necessary and secure tightly.
- 3.4 Repeat for opposing and additional runway lengths.  
NOTE: Maximum distance from splice joint to hanger should be no more than 4".

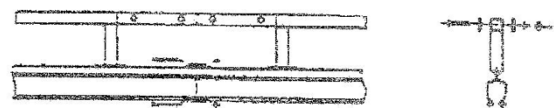

FIG 3A

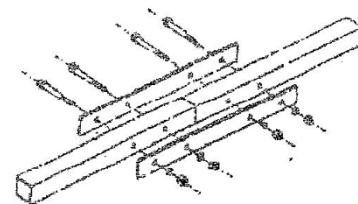
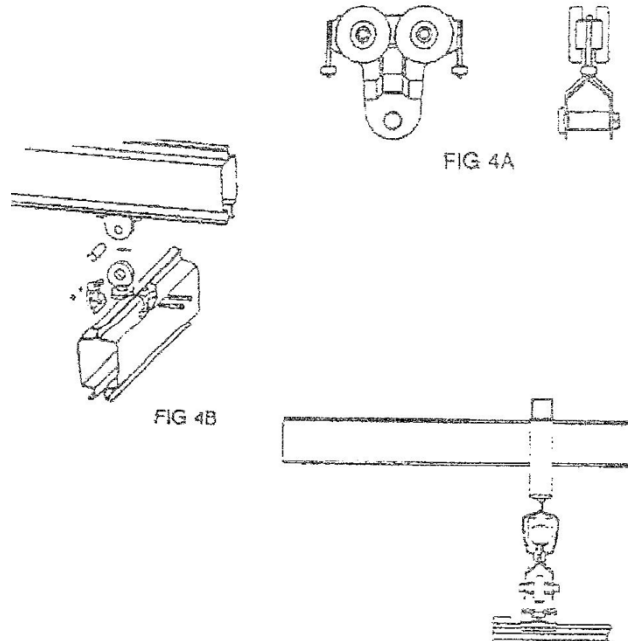

FIG 3B

4.0 Installing Teletwist Trolley and Bridge in Runways

- 4.1 Place teletwist trolley in runway. (FIG 4A)
- 4.2 Make sure runway is clear of particulants or debris by moving the Teletwist trolley the entire distance of the runway.
- 4.3 Repeat for opposing runway.
- 4.4 Attach suspension clamp (supplies) to bridge rail. (FIG 4B)
- 4.5 Attach bridge to Teletwist trolley. Remove pin, align suspension clamp and re-insert pin. (FIG 4)



5.0 Installing Hoist Trolley and End Caps

- 5.1 Making sure there are no obstructions in bridge rail, slide hoist trolley into position. (FIG 5A)
- 5.2 Insert festoon trolley(ies) in bridge rail. (FIG 5B)  
NOTE: 5" of rail= 1 festoon trolley
- 5.3 Install end cap (kit supplies) to both ends of bridge rail. (FIG 5)
- 5.4 Install end cap to both ends of runways.  
NOTE: Hose clamps are optional purchase.

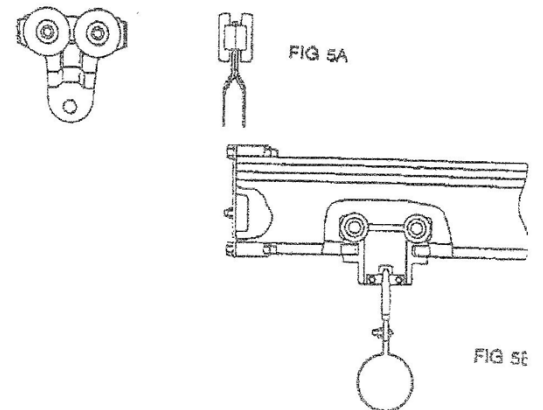

6.0 Leveling Crane System

- 6.1 Shim runways or upright supports to within + or - 1/4" and parallel to within + or - 1/4" over a 10'-0" distance.

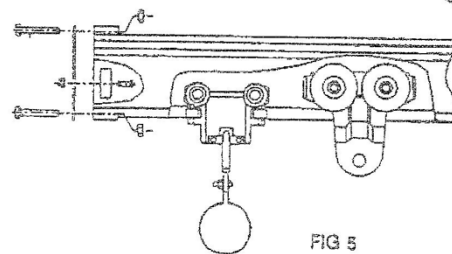

## 7.0 Checklist and Maintenance Schedule

The following checklist and maintenance schedule has been compiled to assist in-house personnel in maintaining a properly functioning crane system. It may be used as a basis for preventative maintenance and for drawing up an overall servicing schedule. This checklist does not specific those regular checklist and inspection which must be carried out daily or at regular intervals in accordance with regulations.

**ALL BOTED CONNECTIONS MUST BE RETIGHTENED ONE OR TWO MONTHS AFTER INSTALLATION.**

Item No.	Equipment	To be checked by: electrician/maintenance	Detailed specifications for checking	3 mths	6 mths	12 mths	2 Yrs
1	Complete installation	Electrician/maintenance	Overall impression, general condition inspects with operations		X		
2	Crane system						X
2.1	Suspension hangers & clamps	Maintenance	-Mounting, damage, wear - Bolted connections on supporting structure (clamps) -Bolted connections of suspension rod (torque = 33ft lbs) - Depth to which threaded rods are screwed (check holes); fit and wear of sliding shell -Bolted connections of track clamping fixtures: hinge sockets -Stress on suspension rod (vertical play) -Crane girder suspension: fit, wear, lubrication of sliding shell -Lubrication of hinges			X	
2.2	Runways	Maintenance	- Dirt - Wear of running surfaces -Wear of edges in track section gap Width of track section gap			X	